

# **Operation & Maintenance Manual**

## **Mini Quick Scrape-N-Grab<sup>TM</sup> Mini Grapple Bucket For Mini Skid Steer Loaders And Mini Track Loaders**



**Read this Manual Before Use**

**TABLE OF CONTENTS**

SAFETY	3-4
SERIAL NUMBER/DECAL LOCATION	5-6
USER'S MOUNTING INSTRUCTIONS	7-8
OPERATING INSTRUCTIONS	9
ROUTINE MAINTENANCE	10
PARTS INFORMATION	11-13
GENERAL SPECIFICATIONS	14
WARRANTY	15

**REFERENCE INFORMATION**

**Write the serial number for your attachment in the spaces below. Always refer to this serial number when calling for service or parts.**

Serial Number.....\_\_\_\_\_

**YOUR ATTACHMENT DEALER**

\_\_\_\_\_  
**ADDRESS:**

\_\_\_\_\_  
**PHONE:**

\_\_\_\_\_  
**CONTACT:**

**NOTE:** *Quick Attach Attachments LLC reserves the right to make improvements in design or changes in specifications at any time without notice and without incurring any obligations to install them on units previously sold.*

# SAFETY

---

**DO NOT use or perform maintenance on this machine until this manual has been read and understood. In addition, read the Operation and Maintenance Manual(s) pertaining to the attachment and the attachment carrier (“Loader”).**

The user is responsible for inspecting the machine daily, and for having parts repaired or replaced when continued use of the machine would cause damage, excessive wear to other parts or make the machine unsafe for continued operation.

If an operating procedure, tool device, maintenance or work method not specifically recommended is used, you must satisfy yourself that it is safe for you and others. You must also ensure that the attachment will not be damaged or made unsafe by the procedures you choose.

Quick Attach Attachments LLC cannot anticipate every possible circumstance that might involve potential hazard. The safety messages found in this manual and on the machine are therefore not all inclusive.

Throughout this manual, reference may be made to the left hand (LH) and right hand (RH) side. These terms are used as viewed from the operator’s seat facing front.

The signal words **CAUTION**, **WARNING**, or **DANGER** are used to indicate hazards.

**⚠ CAUTION** Indicates a potentially hazardous situation which, if not avoided, may result in minor or moderate injury.

**⚠ WARNING** Indicates a potentially hazardous situation which, if not avoided, could result in death or serious injury.

**⚠ DANGER** Indicates a potentially hazardous situation which, if not avoided, will result in death or serious injury.

The word **IMPORTANT** is used in the text when immediate damage will occur due to improper technique or operation.

The word **NOTE** is used to convey information that is out of context with the manual text; special information such as specifications, techniques, reference information, and other information of a supplementary nature.

## Improper operation can cause serious injury or death.

### Pre-operation

- This attachment is designed for handling construction and natural debris only. **NEVER** use this attachment for any other purpose.
- Read the operator's manual for the "Skid Steer Loader." **NEVER** allow untrained people to operate.
- Operating instructions must be given to everyone before operating this attachment and at least once a year thereafter in accordance with OSHA regulations.
- **NEVER** exceed the maximum recommended input power or speed specifications for the attachment. Over-powering or over-speeding the attachment may cause personal injury and/or machine damage.
- Keep all shields, guards, and covers in place.
- Do not modify equipment or add attachments that are not approved by Quick Attach Attachments LLC.
- Use adequate safety warning lights and devices as required by local regulations. Obey all local laws and regulations regarding machine operation on public property.

### Operation

- Always wear eye protection that meets ANSI z87.1 standard or use with an enclosure that provides similar protection.
- Hydraulic connections may be hot after use. Use gloves if connecting or disconnecting after use.
- Check and be sure all operating controls are in neutral before starting the engine.
- Keep people away from loader and attachment when in use. This attachment lifts objects and has moving parts. **NEVER** lift load directly over people – load could fall.
- Always stay in the operator position when using the attachment.

### Operation (continued)

- To avoid electric shock or electrocution, **NEVER** operate the attachment near overhead power lines.
- **NEVER** operate near embankments or terrain that is so steep that rollover could occur.
- Before leaving the operators position, disengage hydraulic drive, lower the attachment to rest flat on the ground, stop engine, set park brake, and wait for all motion to stop.
- **NEVER** place hands near moving parts or clear debris while engine is running.
- **NEVER** lift people.

### Avoid High Pressure Fluids Hazard



- Escaping fluid under pressure can penetrate the skin causing serious injury.
- Avoid the hazard by relieving the pressure before disconnecting hydraulic lines.
- Use a piece of paper or cardboard, NOT BODY PARTS, to check for suspected leaks. Wear protective gloves and safety glasses or goggles when servicing or performing maintenance on hydraulic systems.
- If an accident occurs, see a doctor immediately. Any fluid injected into the skin must be surgically removed within a few hours or gangrene may result.

### Maintenance

- **NEVER** make adjustments, lubricate, clean, or perform any service on the machine while it is in operation.
- Make sure the attachment is serviced on a daily basis. Improper maintenance can cause serious injury or death in addition to damage to the attachment and/or your equipment.

# SERIAL NUMBER AND SAFETY DECAL LOCATIONS

## Serial Number Location:

It is important to refer to the serial number of the attachment when making repairs or ordering parts. Early or later models (identification made by serial number) may use different parts, or it may be necessary to use different procedures in doing a specific operation.

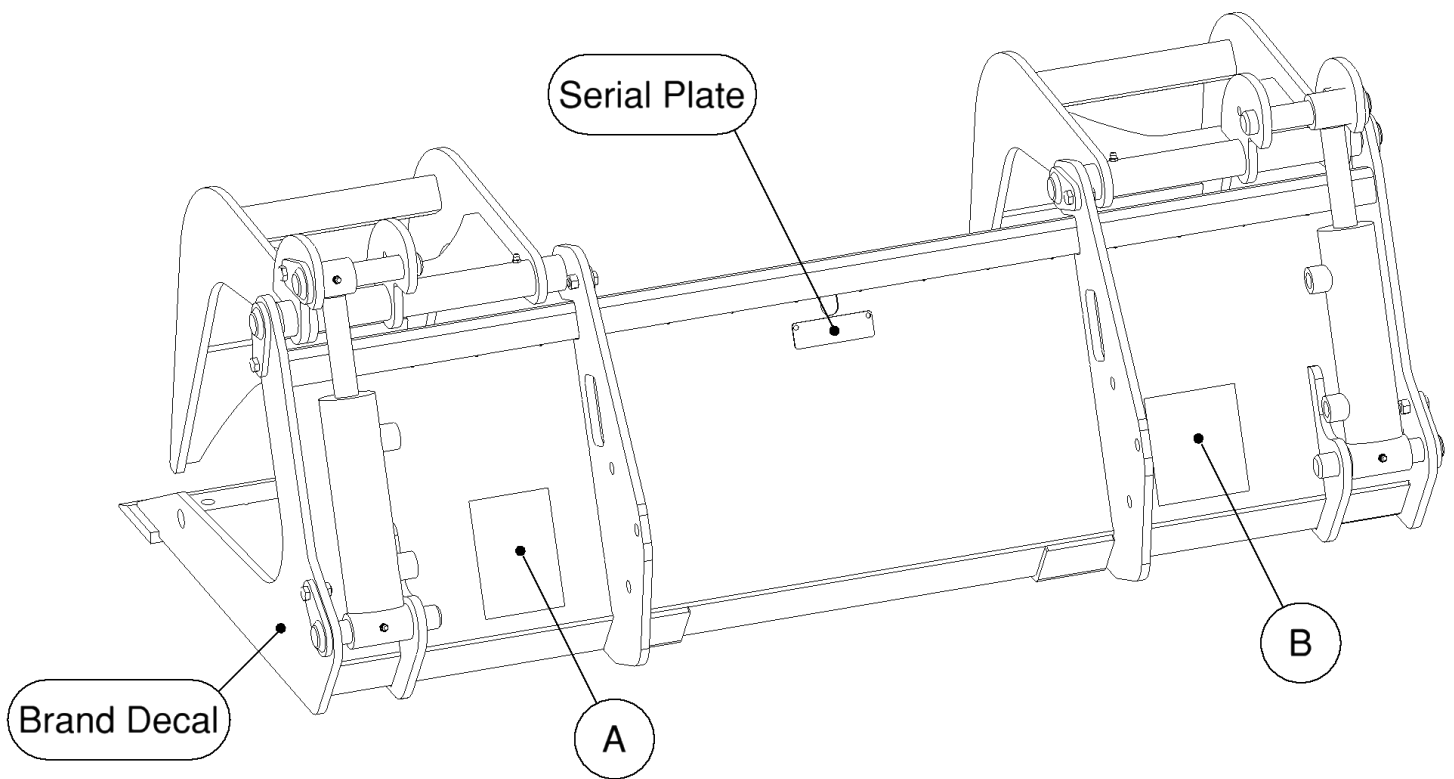

# SERIAL NUMBER AND SAFETY DECAL LOCATIONS

(A)



**Part number: 200001**

**Location:** On back of bucket, left side

**Quantity: 1**

(B)



**Part number: 330901**

**Location:** On back of bucket, right side

**Quantity: 1**

## Mini Brand Decal

**Location:** On each endplate

**Quantity: 2**

## Safety Decals Locations:

The locations of the safety decals are shown. If these decals are missing, damaged, or painted over they must be replaced. Call Quick Attach Attachments LLC (320-759-1551) for replacement decals.

# **USER'S MOUNTING INSTRUCTIONS**

---

After the initial set-up assembly is completed use the following procedure to mount the attachment to the loader for user operation.

**⚠ WARNING** Coupler wedges or pins must extend through holes in attachment. Levers must be fully down and locked. Failure to secure wedges or pins can allow the attachment to come off and cause injury or death.

**IMPORTANT:** This attachment is not designed to be used on loaders with a Rated Operating Capacity (ROC) of more than 1000 pounds.

## **Instructions for mounting to a ride-on mini skid steer:**

1. Use the step, safety treads, and grab handles to get on and off the loader and attachment.
2. Sitting in the operator's seat, lower the seat bar, fasten the seat belt, make sure all controls are in neutral, and start the engine.
3. Drive the loader to the rear of the attachment. Put the loader quick attach coupler into the attachment mounting bracket.
4. Tilt the loader coupler back a small amount until it is fully engaged with the attachment mounting bracket.
5. Stop the engine and engage the park brake.
6. Exit the loader and secure the coupler locking mechanism that locks the attachment to the loader.

## **Instructions for mounting to a walk-behind mini skid steer:**

1. Standing at the operator's station, make sure all controls are in neutral, and start the engine.
2. Drive the loader to the rear of the attachment. Put the loader quick attach coupler into the attachment mounting bracket.
3. Tilt the loader coupler back a small amount until it is fully engaged with the attachment mounting bracket.
4. Stop the engine and engage the park brake.
5. Walk to the front of the loader and secure the coupler locking mechanism that locks the attachment to the loader.

# USER'S MOUNTING INSTRUCTIONS

## Connecting Hydraulics:

1. Connect the hydraulic quick couplers from the attachment to the loader.

**IMPORTANT:** Wipe the ends of the hydraulic quick couplers (both lead and loader) with a rag to remove any possible contamination. Contamination can cause hydraulic components to fail and is not covered under warranty.

**IMPORTANT:** Make sure the quick couplers are fully engaged. If the quick couplers do not fully engage, check to see that the couplers are the same size and brand. Do not force the quick couplers together.

**NOTE:** See the loader's operator's manual for auxiliary hydraulic specifications and connection instructions.

**NOTE:** Attachment is shipped with 8FJX (3/4" Female JIC Swivel) fittings on the ends of the lead hoses.

2. Make sure the hoses are properly routed to fit your specific loader. If the hoses are not routed correctly, hoses may get pinched or rub on tires. Be sure to check the hose routing through the full range of intended motion of the attachment before operating it.

More than one routing may be acceptable depending on the loader. Pick the routing that best suits your specific loader.

**IMPORTANT:** Proper hose routing is the responsibility of the owner and/or operator. Pinched or stretched hoses are not covered under warranty.

Mounting is now complete and the attachment is ready for operation. Use the above instructions in the reverse order to dismount the attachment from the loader.

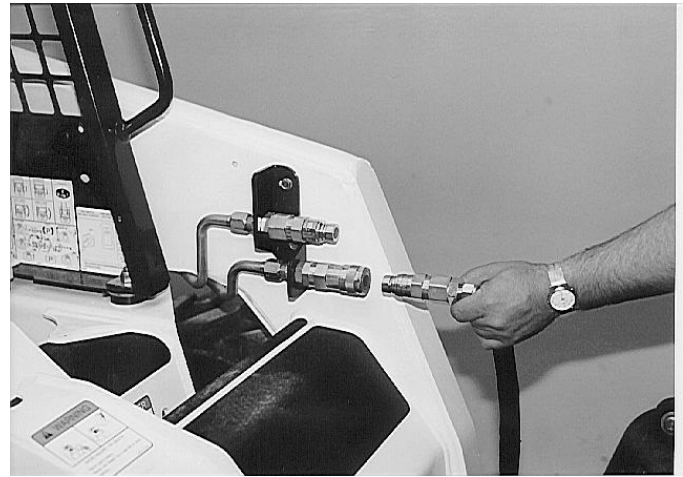

# OPERATING INSTRUCTIONS

---



1. With the operator in the seat of the loader, the seat belt fastened, and the seat bar lowered (if so equipped), start the engine.
2. Raise the attachment slightly off of the ground.
3. Activate the auxiliary hydraulic system to open and close the grapple in order to pick, up and move debris/objects.

**⚠ WARNING** If the grappled object becomes unstable or unbalanced, lower the attachment to the ground and repeat the grapping process until the object being lifted remains stable the entire time it is being lifted and moved. Always lower the object to the ground before opening the bucket to release it.

**⚠ WARNING** To avoid injury or death, do not allow any person to be directly under the attachment or load at any time.

**⚠ CAUTION** Carry load as low as possible to avoid serious injury or death from tipping or falling load.





# ROUTINE MAINTENANCE

**⚠ WARNING** Lower the attachment to rest flat on the ground, shut down the engine, relieve the hydraulic pressure to the attachment, set the park brake, and wait for all motion to stop before leaving the operator's seat to perform service of any kind.

It is the operator's responsibility to make daily inspections of the loader and attachment for damage, loose bolts, fluid leaks, or anything else that could cause a potential service or safety problem. Preventive maintenance is the easiest and least expensive type of maintenance.

**IMPORTANT:** Bolts can loosen after initial usage. After the first hour of operation check all bolts.

## LUBRICATION

<b>Lubrication Legend</b>	 Multipurpose spray lube	 No. 2 Lithium base gun grease	 Clean engine oil	 <b>50</b> Intervals at which lubrication is required
---------------------------	---	---	--	--

Use No. 2 lithium base gun grease when lubricating all attachment grease fittings.

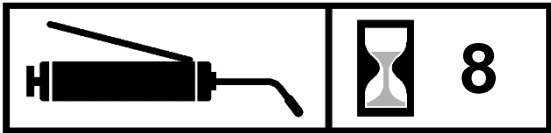

Grease all four hinge bushings **[A]** every **8 hours** of operation, or more frequently during heavy use.

Grease all four cylinder zerks **[B]** every **8 hours** of operation, or more frequently during heavy use.

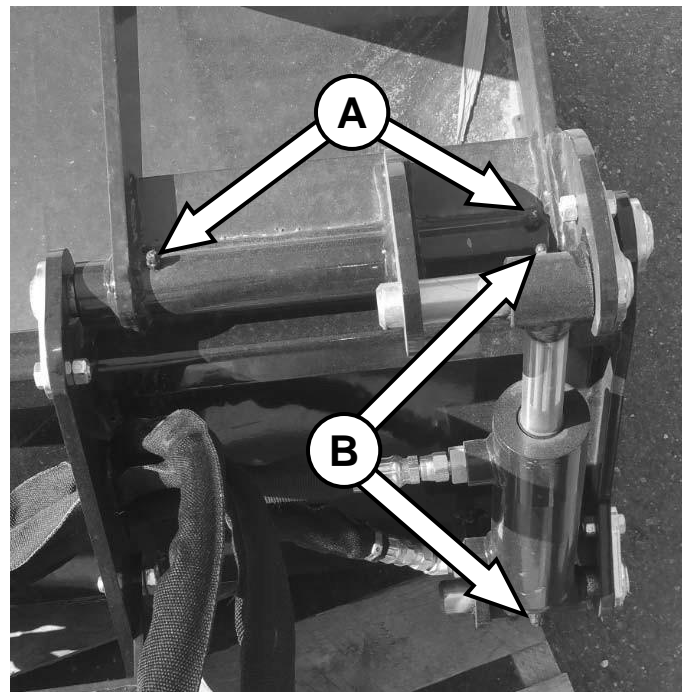

### Tooth Replacement (Optional Tooth Bar)

1. Securely block up the attachment to allow access to the teeth to be replaced.
2. Using a punch and a hammer, pound out the pin and remove the tooth.
3. Use the reverse order to install the new tooth. A vise grip or pliers may be helpful to hold the pin while installing. Use the hammer directly on the pin, the punch is not necessary during installation.

**IMPORTANT:** Make sure the pin I installed with the side labeled "BACK" facing away from the tip (front) of the tooth.

**NOTE:** When replacing teeth, always use new pins during installation.



# PARTS INFORMATION

ITEM	QTY	PART NO.	DESCRIPTION	STOCK NO.
1	2	400074	CYLINDER 2 X 4 W/BUSHINGS	
2	2	400529	HOSE 3/8 X 65" 8FJX-6FJX90	LEAD
3	4	400528	HOSE 3/8 X 21" 6FJX-6FJX	
4	2	203088	ADPT TEE 6MJ-6MJ-6MJ	
5	2	201925	ADPT STR 8MB-6MJ	CYL ROD
6	2	300274	ADPT ELB 8MB-6MJ-45	CYL BASE

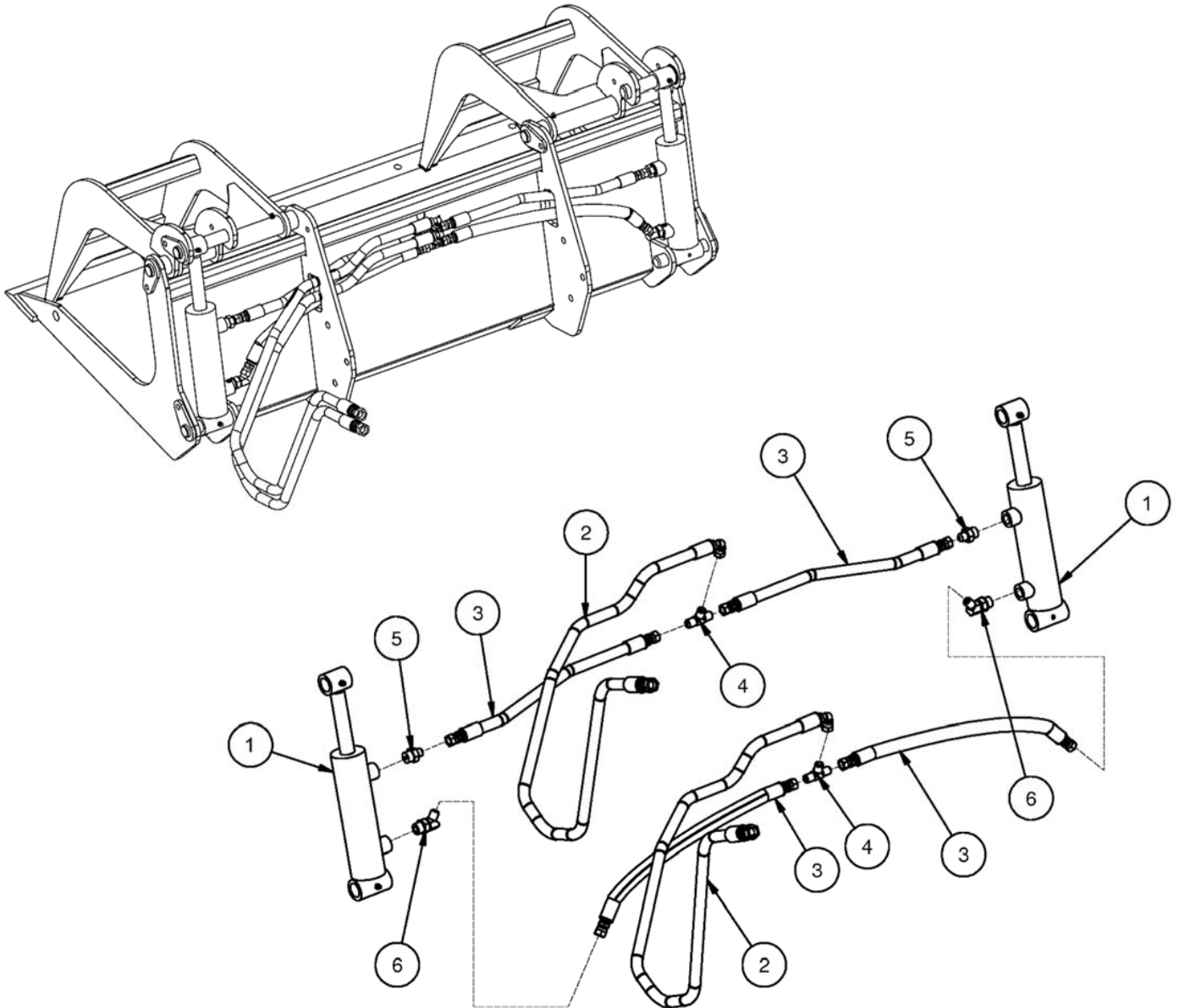

## PARTS INFORMATION

ITEM	QTY	PART NO.	DESCRIPTION	STOCK NO.
1	1	400756	GRAPPLE BUCKET 48 W/A	
2	1	400501	ROD BUCKET GRAPPLE LH W/A	
3	1	400502	ROD BUCKET GRAPPLE RH W/A	
4	4	316026	PIN 1 X 5 W/A	
5	4	400041	PIN 1 X 4 W/A	
6	8	13105	BOLT HEX	<b>3/8 X 1 NC GR5</b>
7	8	37212	NUT REV LOCK	<b>3/8 NC</b>
8	1	400000	MOUNT FRAME TORO MINI W/A	<b>OPT MNT PKG 400540</b>
9	1	400001	MOUNT FRAME ASV MINI W/A	<b>OPT MNT PKG 400541</b>
10	1	400002	MOUNT FRAME BC MINI W/A	<b>OPT MNT PKG 400542</b>
11	1	330622	MOUNT FRAME AVANT MINI W/A	<b>AVANT ADPT MNT PKG 330753</b>
12	6	15209	BOLT 1/2 X 1-1/2 NC GR 8	<b>OPT MNT PKG</b>
13	1	400099	TOOTHBAR 48 W/A	<b>OPT TOOTH BAR</b>
14	5	312263	TOOTH BUCKET PIN ON	<b>OPT TOOTH BAR</b>
15	5	312265	PIN FLEX TOOTHBAR/ROD BKT	<b>OPT TOOTH BAR</b>
16	4	33018	WASHER FLAT USS 3/4	<b>OPT TOOTH BAR</b>
17	2	13361	BOLT 3/4 X 2 NC GR 5	<b>OPT TOOTH BAR</b>
18	2	37217	NUT REV LOCK 3/4 NC GR5	<b>OPT TOOTH BAR</b>
19	1	400111	CUTTING EDGE B 1/2 X 4 X 49.5	<b>OPT BOLT ON CUT EDGE PKG 400053</b>
20	5	22644	BOLT PLOW 1/2 X 1-3/4 NC GR5	<b>OPT BOLT ON CUT EDGE PKG 400053</b>
21	5	33626	WASHER LOCK 1/2	<b>OPT BOLT ON CUT EDGE PKG 400053</b>
22	5	36110	NUT FULL HEX 1/2 NC GR 5	<b>OPT BOLT ON CUT EDGE PKG 400053</b>
23	6	0167011	NUT FLG TOP LOCK 1/2 NC GR 8 YZ	<b>OPT MNT PKG</b>

# PARTS INFORMATION

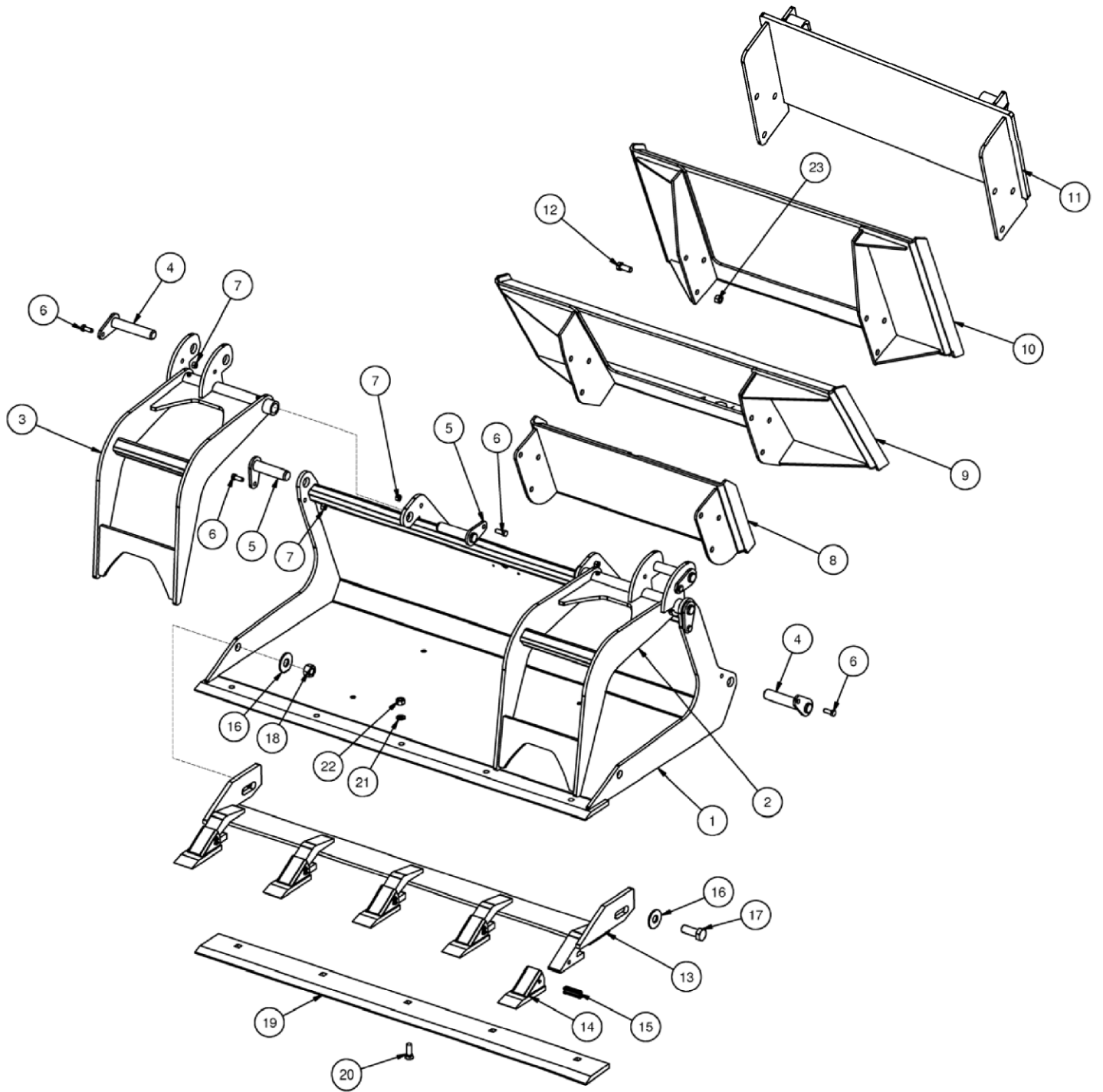

# GENERAL SPECIFICATIONS

Model	Mini Grapple Bucket
Working Width	48"
Overall Width	49.75"
Height – Grapples Closed	20.41"
Length (w/out mount)	28.21"
Max Grapple Opening	27"
Number of Hydraulic Cylinders	2
Operating Weight (w/out mount)	240 lbs.

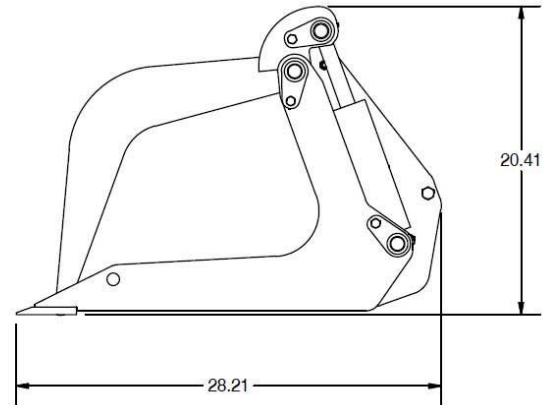
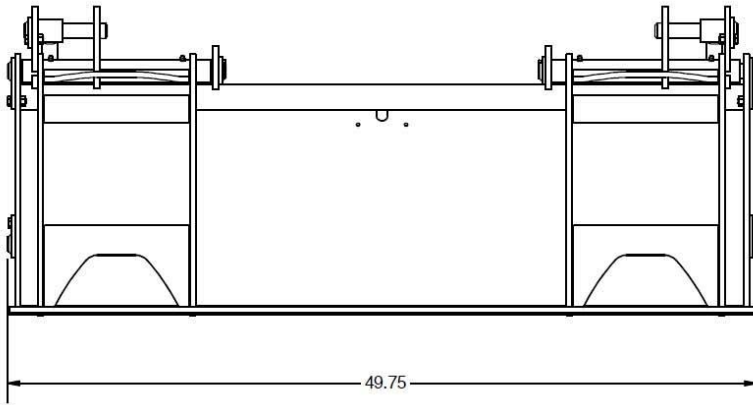

All dimensions are in INCHES.

## Torque-Tension Relationships for SAE J429 Grade Bolts

Nominal Thread Size	SAE J429 Grade 2			SAE J429 Grade 5			SAE J429 Grade 8		
	Clamp Load (lbs)	Tightening Torque		Clamp Load (lbs)	Tightening Torque		Clamp Load (lbs)	Tightening Torque	
		K = .15	K = .20		K = .15	K = .20		K = .15	K = .20
<b>Unified Coarse Thread Series</b>									
1/4-20	1,300	49 in-lbs	65 in-lbs	2,000	75 in-lbs	100 in-lbs	2,850	107 in-lbs	143 in-lbs
5/16-18	2,150	101	134	3,350	157	210	4,700	220	305
3/8-16	3,200	15 ft-lbs	20 ft-lbs	4,950	23 ft-lbs	31 ft-lbs	6,950	32.5 ft-lbs	44 ft-lbs
7/16-14	4,400	24	30	6,800	37	50	9,600	53	70
1/2-13	5,850	36.5	49	9,050	57	75	12,800	80	107
9/16-12	7,500	53	70	11,600	82	109	16,400	115	154
5/8-11	9,300	73	97	14,500	113	151	20,300	159	211
3/4-10	13,800	129	173	21,300	200	266	30,100	282	376
7/8-9	11,425	125	166	29,435	321	430	41,550	454	606
1-8	15,000	187.5	250	38,600	482.5	640	54,540	680	900
<b>Unified Fine Thread Series</b>									
1/4-28	1,500	55 in-lbs	75 in-lbs	2,300	85 in-lbs	115 in-lbs	3,250	120 in-lbs	163 in-lbs
5/16-24	2,400	112	150	3,700	173	230	5,200	245	325
3/8-24	3,600	17 ft-lbs	22.5 ft-lbs	5,600	26 ft-lbs	35 ft-lbs	7,900	37 ft-lbs	50 ft-lbs
7/16-20	4,900	27	36	7,550	42	55	10,700	59	78
1/2-20	6,600	41	55	10,200	64	85	14,400	90	120
9/16-18	8,400	59	79	13,000	92	122	18,300	129	172
5/8-18	10,600	83	110	16,300	128	170	23,000	180	240
3/4-16	15,400	144	193	23,800	223	298	33,600	315	420
7/8-14	12,610	138	184	32,480	355	473	45,855	500	668
1-12	16,410	205	273	42,270	528	704	59,670	745	995

Clamp load estimated as 75% of proof load for specified bolts.

Torque values for 1/4 and 5/16 inch series are in inch-pounds. All other torque values are in foot-pounds.

Torque values calculated from formula  $T = KDF$

where:  $K=0.15$  for "lubricated" conditions

$K=0.20$  for "dry" conditions



## **LIMITED WARRANTY**

Quick Attach Attachments LLC warrants each new machine manufactured by us to be free from defects in material and workmanship for a period of twelve (12) months from date of delivery to the original purchaser.

Our obligation under this warranty is to replace free of charge, at our factory or Direct Outlet locations, any part proven defective within the stated warranty time limit.

All parts must be returned freight prepaid and adequately packaged to prevent damage in transit.

This warranty does not cover:

1. New products which have been operated in excess of rated capacities or negligence
2. Misuse, abuse, accidents or damage due to improperly routed hoses
3. Machines which have been altered, modified or repaired in any manner not authorized by our company
4. Previously owned equipment
5. Any ground engaging tools in which natural wear is involved, i.e. tooth tips, cutting teeth, etc
6. Normal maintenance
7. Fork tines
8. Hydraulic motors that have been disassembled in any manner

In no event will the Sales Representative, Direct Outlet, Quick Attach Attachments LLC, or any other company affiliated with it or them be liable for incidental or consequential damages or injuries, including but not limited to the loss of profit, rental or substitute equipment or other commercial loss. Purchaser's sole and exclusive remedy being as provided here in above.

Quick Attach Attachments LLC must receive immediate notification of defect and no allowance will be made for repairs without our consent or approval.

This warranty is in lieu of all other warranties, express or implied by law or otherwise, and there is no warranty of merchantability or fitness purpose.

No agent, employee, or representative of Quick Attach Attachments LLC has any authority to bind Quick Attach Attachments LLC to any warranty except as specifically set forth herein. Any of these limitations excluded by local law shall be deemed deleted from this warranty; all other terms apply.

This warranty may not be enlarged or modified in any manner except in writing signed by an executive officer of Quick Attach Attachments LLC to improve its products whenever it is possible and practical to do so. Quick Attach Attachments LLC reserves the right to make changes and or add improvements at any time without incurring any obligation to make such changes or add such improvements to products previously sold.

Quick Attach Attachments LLC  
P.O. Box 128 Alexandria, MN56308  
Phone (320) 759-1551 Fax (320) 759-1590



**P/N 400759**  
Quick Attach Attachments LLC

**Date Printed: 2/4/2020**

Printed in U.S.A.